

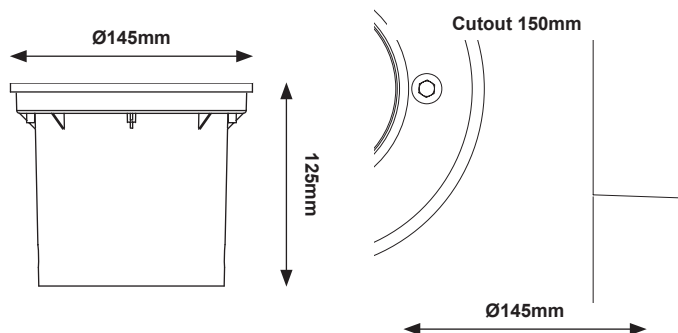

# Installation Instructions GU10 Asymmetrical Ground Light

Product Code: 3739



**Please read instructions carefully.**

**This product should only be installed by a qualified electrician**

**Please retain these instructions for future reference.**

## Features

- The body of the lamp is made of high-pure aluminum, electrostatic coating and thermostatic hardening.
- Strong and durable, dust-proof and waterproof.
- Can be used in: interior decoration, outdoor corridor, garden, warehouse etc.

Code	Cutout	Lampholder	Rating	Rated power	Protection	IP Rating
3739	150mm	GU10	240V 50Hz	50W	CLASS 1	IP67

## INSTALLATION INSTRUCTIONS

- Ensure electricity is switched off at the mains before installation
- Prepare all parts which the fitting needs.
- Use waterproofed cable H05RN-F 3\*1.0mm<sup>2</sup>
- Install the plastic box as per its cutout dimensions.
- Attach fitting cable to power supply
- Once plastic box is fastened in the hole, screw the lamp housing inside plastic box, secure the stainless steel cover well, then turn on the power.

## Warning

**This product should only be installed by a qualified electrician.**

**Discard if the housing or glass cover is damaged**

## PRODUCT END OF LIFE INSTRUCTION.

This Lighting product is in the scope of EU 2019/2020 directive on Waste Electrical and Electronic Equipment (WEEE). This product must be disposed of according to the legislation. This document is intended for use by end of life recyclers or treatment facilities. It provides the basic information to assure an appropriate end of life treatment for the components and materials of the product. Please follow pictured diagram showing how to dismantle the product into different components which should be disposed of correctly. These components consist of plastic, metal and electronic materials. It is the responsibility of the end user to dispose of this product correctly.

Contact: [www.weeeireland.ie](http://www.weeeireland.ie) or contact your local council for further information.

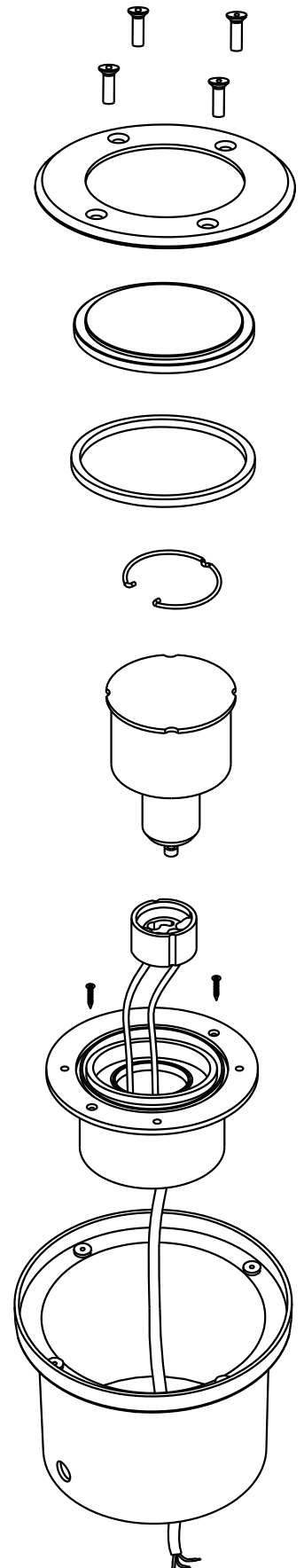

For more information contact:

Unit 7/8 Ashbourne Business Centre, Ballybin Road, Ashbourne, Co. Meath, Ireland, A84 YP58,  
**Phone:** 00353 1 835 7447



Solas Geal Distribution

Unit 32 Junction One Business Park, Valley Road, Birkenhead, Merseyside, UK, CH41 7ED,  
**UK Ph:** 0330 551 7000

**Website:** [www.sgd.ie](http://www.sgd.ie)



## EU DECLARATION OF CONFORMITY

**Manufacturers Name:** Solas Geal Distribution  
Unit 7/8 Ashbourne Business Centre, Ballybin Road, Ashbourne, Co. Meath, A84 YP58.

**Declaration Number:**  
061-3732, 061-3732SQ, 061-3739,

This declaration of conformity is issued under the sole responsibility of the manufacturer.

**Products:**  
IP67 LED Ground lights

**Model Number:**  
3732, 3732SQ, 3739

The product/model of the declaration described above is in conformity with the relevant  
Community harmonisation legislation:

**Low Voltage Directive (2014/35/EU)**  
**EMC (2014/30/EU)**

The product/model of the declaration described above is in conformity with the standards  
and technical specifications listed below:

EN60598-2-13:2006+A1:12, EN60598-1:2015, EN62493:2015, EN55015:2013/+A1:2015,  
EN61547:2009, EN61000-3-2:2014, EN61000-3-3:2013



3732



3732SQ



3739

*Signed:*

*Date:*

*Place of Issue: Republic of Ireland*

