



Code	Description
SHBMW	LED Multi Watt CCT High Bay Light
SHBSENS	Microwave Sensor accessory for High Bay
RC-HB	Remote Control for High Bay

## LED MULTI WATT CCT HIGH BAY LIGHT

### FEATURES:

- Multi Watt: 100w, 150w, 200w
- 160 Lm/Watt
- CCT: 4000k, 5000k, 6000k
- >Ra80
- IP Rating IP65
- Beam Angle:120°
- Input Voltage: 100-240V 50/60Hz
- Mounting Bracket Included
- Dimmable (with sensor only)
- Supplied with 1M Cable
- Remote Control (sold separately)
- Microwave sensor attachment (sold separately)



Microwave Sensor



Remote Control

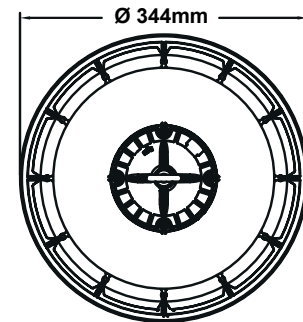

### Description of dialling gear

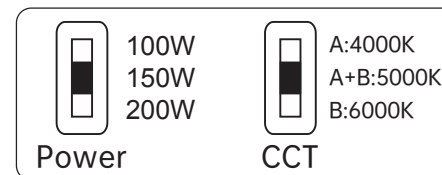

Solas Geal Distribution Ltd, Unit 7 & 8 Ashbourne Business Centre, Ballybin Road, Ashbourne, Co. Meath, A84 YP58, Ireland.  
 SGD Solas Geal UK Ltd, Unit 32 Junction One Business Park, Valley Road, Birkenhead, Wirral, Merseyside, UK, CH41 7ED.

Tel: +353 1 8357447. UK Ph: 0330 551 7000. Fax: 00353 1 8357448. Email: info@sgd.ie. Website: www.sgd.ie